



PROFESSIONAL LIFTING EQUIPMENT

WHEN SAFETY DEPENDS ON PERFORMANCE!

72040

Brake Drum Handler

INTENDED USE

Designed for removing, installing and transporting outboard mounted brake drums and inboard mounted drums with disc wheel hubs.

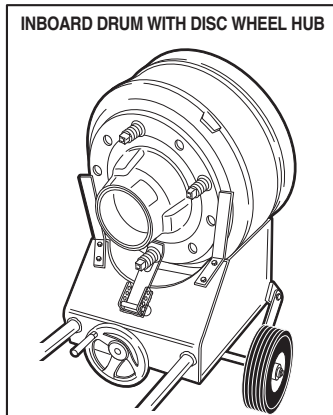
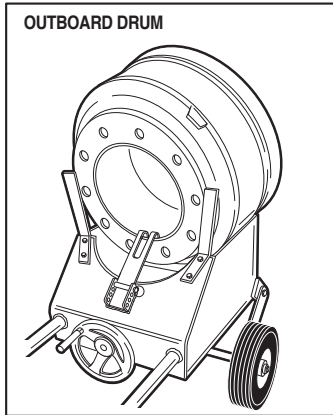

FEATURES

- Reduces lost-time injuries.
- Handles 15" and 16-1/2" drums.
- 35 1/2" handle for easy positioning during installation & removal.
- Rotating handle provides ease of raising and lowering drum.
- Ball bearing wheels, semi-pneumatic tires and 3/4" diameter axle provide easy maneuverability and balance of drum.
- Adjustable angle bracket secures both outboard and inboard mounted drums with disc wheel hubs to the drum handler's carriage.
- Detachable handle for convenient storage.



MODEL NUMBER	LIFT HEIGHT		OVERALL DIMENSIONS		SHIPPING WEIGHT
	Low	High	Length	Width	
72040B	10.25"	15.25"	62.5"	21"	64 lbs.